

Parts List 2442 Series

Effective: December 15, 2001
Supersedes: P410-2442 Dated April 2001

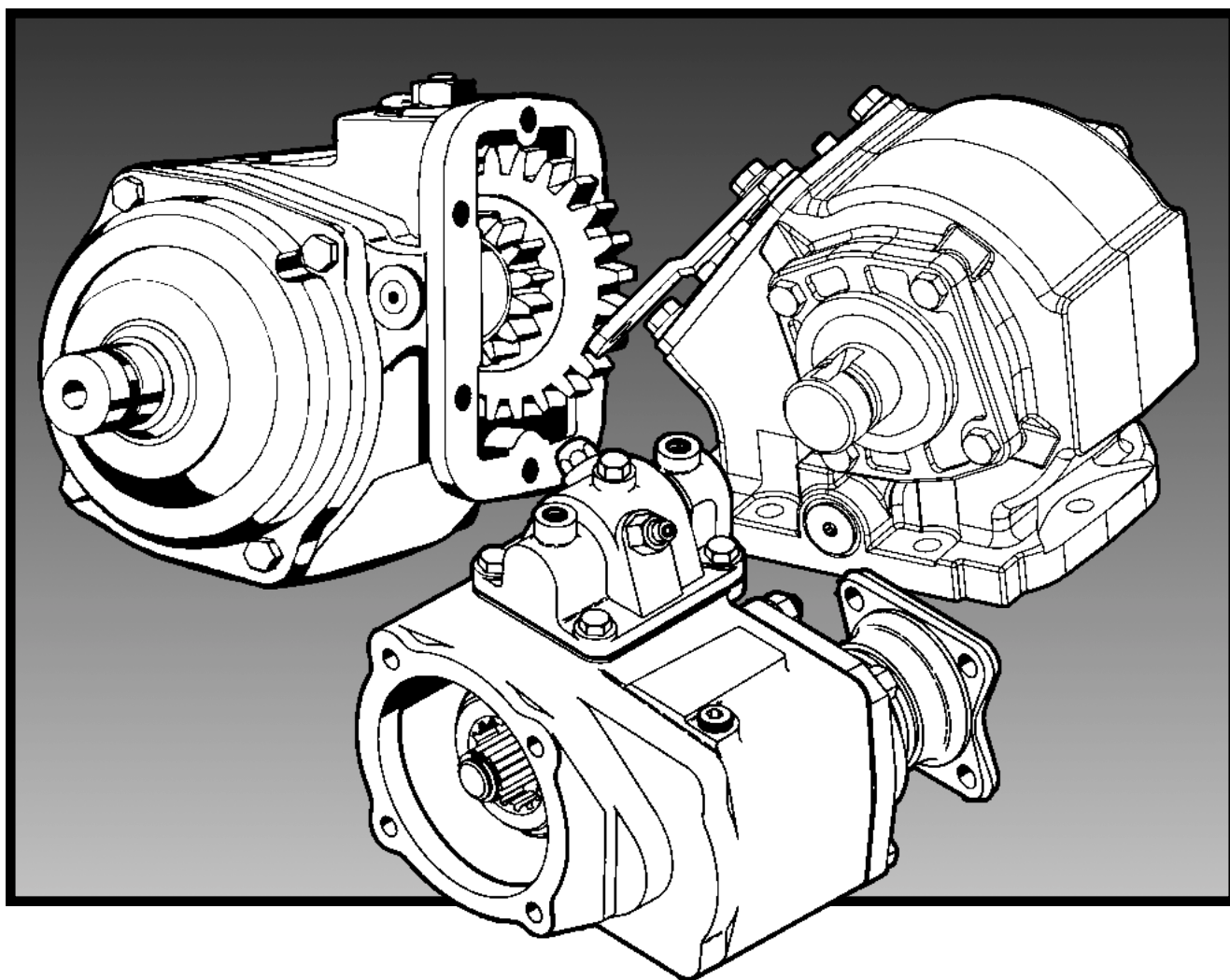

 **WARNING**

FAILURE OR IMPROPER SELECTION OR IMPROPER USE OF THE PRODUCTS AND/OR SYSTEMS DESCRIBED HEREIN OR RELATED ITEMS CAN CAUSE DEATH, PERSONAL INJURY AND PROPERTY DAMAGE.

This document and other information from Parker Hannifin Corporation, its subsidiaries and authorized distributors provide product and/or system options for further investigation by users having technical expertise. It is important that you analyze all aspects of your application and review the information concerning the product or system in the current product catalog. Due to the variety of operating conditions and applications for these products or systems, the user, through its own analysis and testing, is solely responsible for making the final selection of the products and systems and assuring that all performance, safety and warning requirements of the application are met.

The products described herein, including without limitation, product features, specifications, designs, availability and pricing, are subject to change by Parker Hannifin Corporation and its subsidiaries at any time without notice.

Offer of Sale

The items described in this document are hereby offered for sale by Parker Hannifin Corporation, its subsidiaries or its authorized distributors. This offer and its acceptance are governed by the provisions stated in the "Offer of Sale".

© Copyright 2001, Parker Hannifin Corporation, All Rights Reserved

Contents

Exploded View (100 Series)	1
Bill of Materials (100 Series)	2
Exploded View (442 Series)	3
Bill of Materials (442 Series)	4-5
Gear Chart	5
Lever Control Parts (“Y” Designator)	6
Air Shift Control Parts (“A” Designator)	7
E-Z Shift™ Parts (“Z” Designator)	8
Direct Mount Pump Conversion	9
Pump Conversion Kits Bill of Materials	10
Pump Flange and Shaft Dimensions	11
P.T.O. Housing Dimensions	12
Assembly Arrangements	13
Model Number Designation	13
Offer of Sale	16

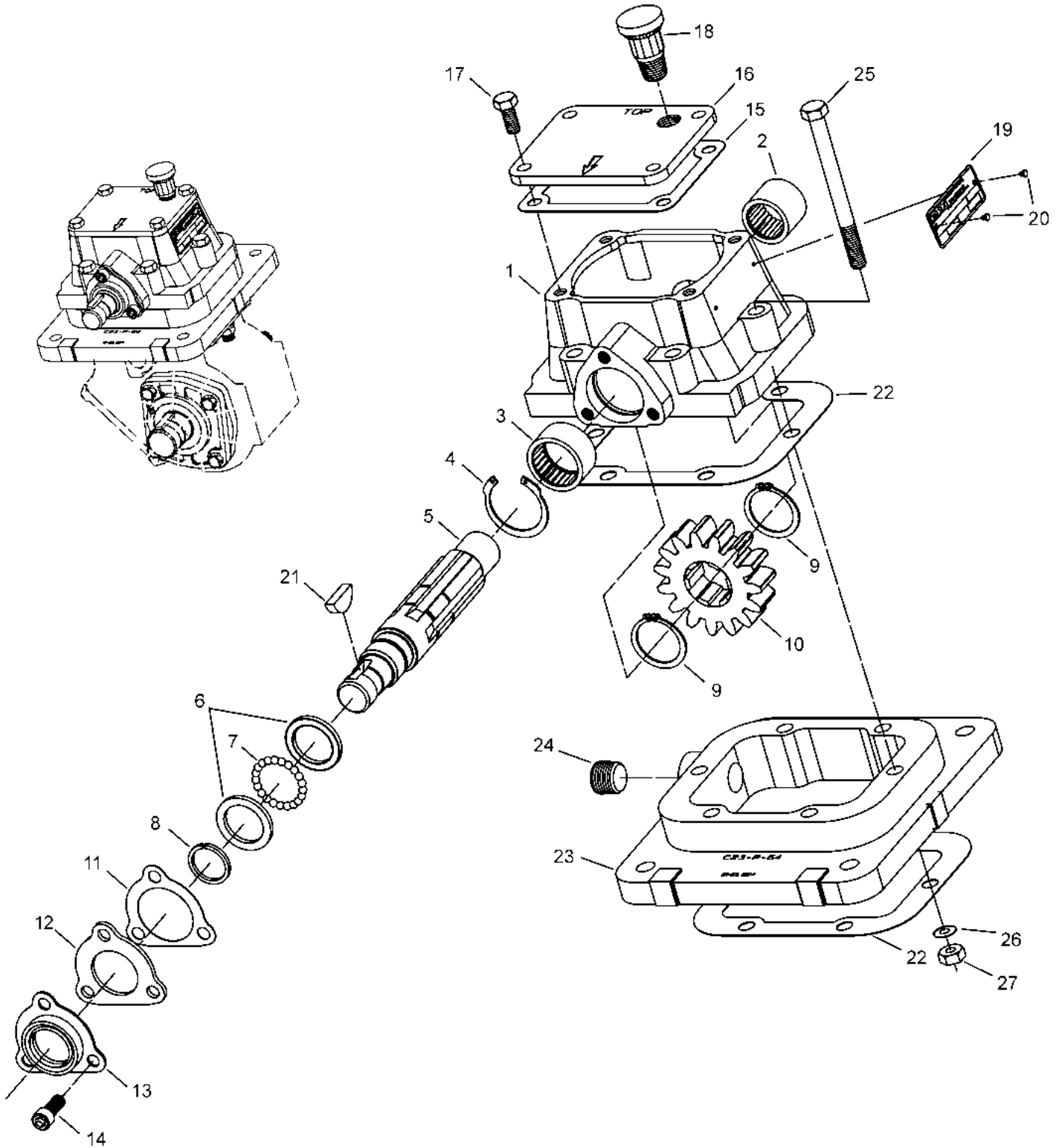

Item	Part Number	Description	Quantity
	328853X	SPECIAL 100 SERIES SUB-ASSEMBLY (Include 328852-1X 1 and 328281-73X plus items 9-20)	1
	328852-1X	HOUSING AND BEARING ASSEMBLY (Include items 1-4)	1
1	1-P-393	Housing	1
2	550895	Needle Bearing	1
3	550135	Needle Bearing	1
4	379124	Lockring	1
	328281-73X	DRIVE SHAFT ASSEMBLY (Includes items 5-8)	
5	3-P-350	Drive Shaft	1
6	31-P-79	Thrust Washer	2
7	378108	Ball Bearings	21
8	378331	Lockring	1
9	378333	Lockring	2
10	2-P-290	Drive Gear	1
11	22-P-69	Gasket	1
12	378106	Thrust Plate	1
13	28-P-226	Thrust Bearing Cap and Seal	1
14	378447-4	Capscrew, Socket Head w/Patch (.3125" -18 x .750")	3
15	35-P-57	Cover Plate Gasket	1
16	34-P-110	Cover Plate	1
17	378430-6	Capscrew, Hex Head w/Patch (.3125" - 18 x .625")	3
18	378513	Breather	1
19	68-P-2	Name Plate, English	1
20	378422-1	Drive Screws	2
21	500007-24	Woodruff Key	1
22	35-P-9-1	Mounting Gasket (.010 Thick)	A.R.
22	35-P-9-2	Mounting Gasket (.020 Thick)	A.R.
23	23-P-55	Spacer Mounting Plate	1
24	379064	Pipe Plug (Patched) (.500" - 14 N.P.T.)	1
25	379286-31	Capscrew, Hex Head w/ Patch (.375" - 16 x 4.250")	6
26	500357-11	Lockwasher	6
27	500370-3	Hex Nut (.375" - 16)	6

A.R. — As Required

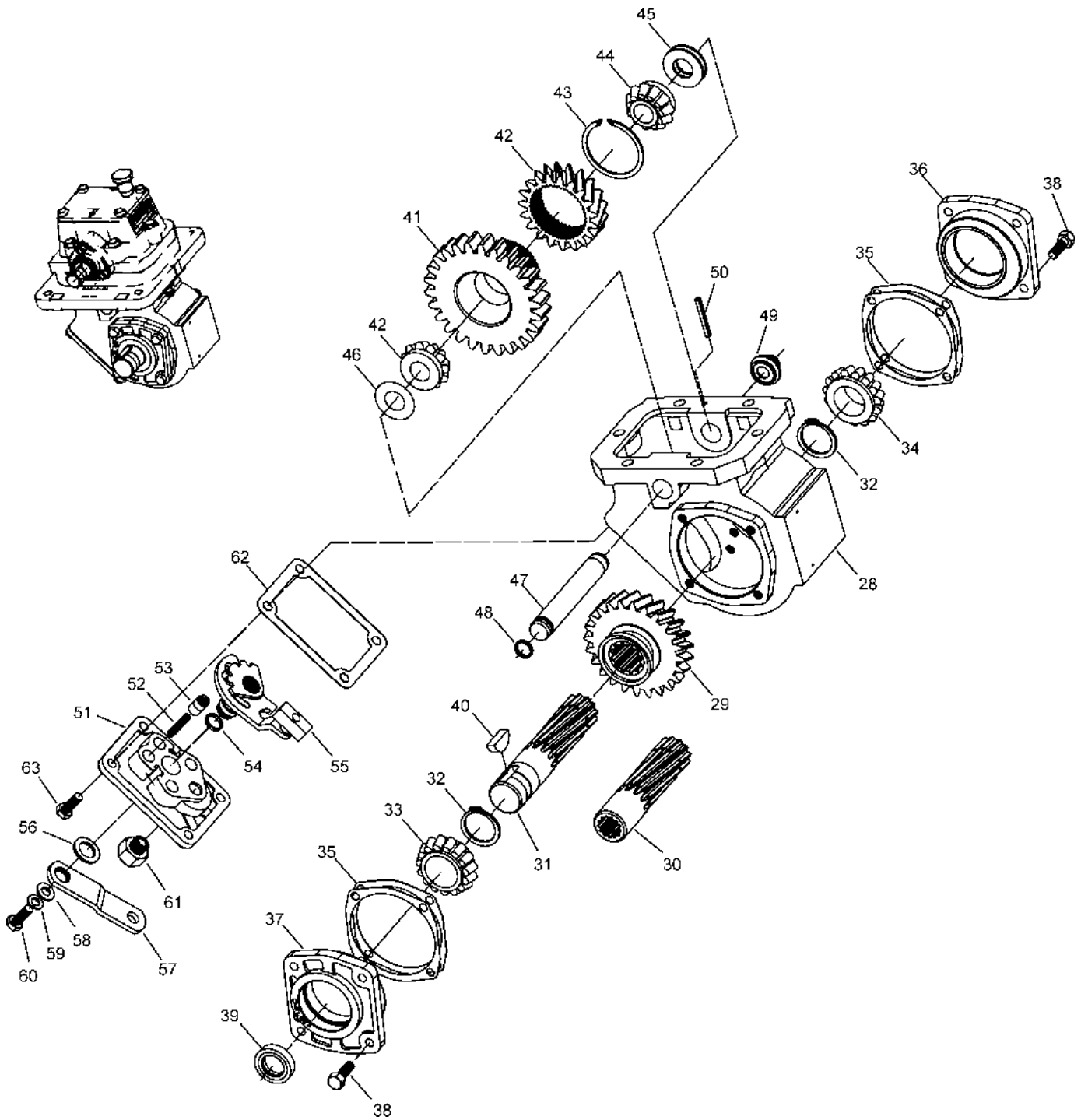

Item	Part Number	Description	Quantity
28	1-P-557X	Housing, Standard Mount (Includes Item 23)	1
29	See Chart, Page 5	Output Gear	1
30	See Chart, Page 5	Output Shaft, Pump Mount	1
31	3-P-202	Output Shaft ("XD") Standard 1.250" Rd. .313" K.W.	1
32	378391	Lockring (All other shifter types)	2
33	550397	Bearing Cone	1
34	550532	Bearing Cone	1
35	22-P-24-1	Bearing Cap Gasket (.010)	AR
	22-P-24-2	Bearing Cap Gasket (.020)	AR
	22-P-24-3	Bearing Cap Gasket (.015)	AR
36	328274X	Bearing Cap Ass'y, Close End	1
NS	550221	Bearing Race	1
37	328273X	Bearing Cap Ass'y, Open End	1
NS	550221	Bearing Race	1
	See Chart, Page 10	Bearing Cap Ass'y, Pump Mount	1
38	378430-10	Capscrew, Hex Head (.312"-18 X 1.00")	4
39	28-P-216	Oil Seal, XD Output	1
	See Chart, Page 10	Oil Seal	1
40	500007-29	Key, Woodruff	1
41	See Chart, Page 5	Input Gear	1
42	See Chart, Page 5	Input Ratio Gear	1
43	379522	Lockring	1
44	550439	Bearing Cone	2
45	14-P-73-1	Idler Gear Spacer (.149-.151)	AR
	14-P-73-2	Idler Gear Spacer (.152-.154)	AR
	14-P-73-3	Idler Gear Spacer (.155-.157)	AR
	14-P-73-4	Idler Gear Spacer (.158-.160)	AR
	14-P-73-5	Idler Gear Spacer (.161-.163)	AR
46	31-P-102	Thrust Washer, Bearing	1
47	9-P-88	Idler Shaft, Standard	1
48	28-P-191	O-Ring	1
49	379672	Plug, O-Ring w/Socket Face (NWD Plug)	1
50	500597-16	Roll Pin (1.125" long), Standard Mount	1
		CABLE CONTROL COVER ASSEMBLIES	
		For Ratios Q, W, X	
	329119-1X	Shifter Cover Assy, Wire Control (Assy 3 & 6)	1
		For Ratios F, L, R, S, U	
	329121-1X	Shifter Cover Assy, Wire Control (Assy 3 & 6)	1
		All the above shift cover assemblies include items 51 thru 62	
51	34-P-74	Cover Plate, Shifter	1
52	37-P-19	Spring	1
53	63-P-16	Poppet Pin	1
54	28-P-191	O-Ring	1
		POST AND PLATE ASS'Y FOR RATIOS Q,W, & X	
55	329118-1X	FOR ASSEMBLIES 3 & 6	1
		POST AND PLATE ASS'Y FOR RATIOS F, H, L, R, S, & U	
55	329120-1X	FOR ASSEMBLIES 3 & 6	1
56	378004	Flat Washer	1
57	51-P-22	Shifter Lever	1
58	500365-22	Flat Washer	1
59	500356-10	Lockwasher	1
60	500409-6	Capscrew, Hex Head (.312"-24 X .625")	1
61	379639	Indicator Switch, Pin Style (Normally Off)	1
62	35-P-8	Gasket, Shifter Cover	1
63	378430-9	Capscrew, Hex Head (.312"-18 X .875") (Wire Shift)	4

A.R. — As Required NS — Not Shown

Input Gear Chart

Item	Part Number	Description	Quantity
		PARTS SHIPPED LOOSE	
	328380X	Wire Control Parts Bag ("W" Shifter)	1
	328346-15X	Wire Control Cable ("W" Shifter)	1
	328751X	Installation Kit ("W" & "Y") Shifter	1
	328711X	Pump Mounting Kit ("XR" Output)	1
	329166-12X	Electric Shift Installation Kit	1
	328948-10X	Split Shaft Installation Instructions	1
	328388-37X	Air Shift Installation Kit ("A" Shifter)	1
	328388-47X	Air Shift Installation Kit ("P" Shifter)	1
	328388-48X	Air Shift Installation Kit ("Q" Shifter)	1
	328388-65X	Air Shift Installation Kit ("S" Shifter)	1
		SERVICE KITS	
	328356-14X	Gasket and Seal Kit (Top Unit, 100 Series)	1
	328356-13X	Gasket & Seal Kit	1
	328356-15X	Shift Cover Seal Kit (Wire Control)	1
	328356-26X	Shift Cover Seal Kit (Lever Control)	1
	328356-17X	Shift Cover Seal Kit (Air Shift)	1
	329202X	Indicator Switch Connector Service Kit	1
	329218X	Indicator Switch Kit	1

Input Gear Chart (Item 41)

Model Number	Part Number	Helix Angle	Number Teeth "A"	Number Teeth "B"
2442**AH	5-P-1004	Spur	22	
2442*FAH	5-P-1077	Spur	22	21

Gear Chart

Ratio Gear Chart (Item 42)		
Ratio	Part Number	Number Teeth
L	5-P-964	25
Q	5-P-965	19
S	5-P-966	24
U	5-P-967	26
W	5-P-968	26
X	5-P-969	38

Output Gear Chart (Item 29)		
Ratio	Part Number	Number Teeth
F	2-P-726	37
L	2-P-727	34
Q	2-P-559	24
S	2-P-637	22
U	2-P-560	20
W	2-P-561	17
X	2-P-728	21

Lever Control Parts ("Y" Designator)

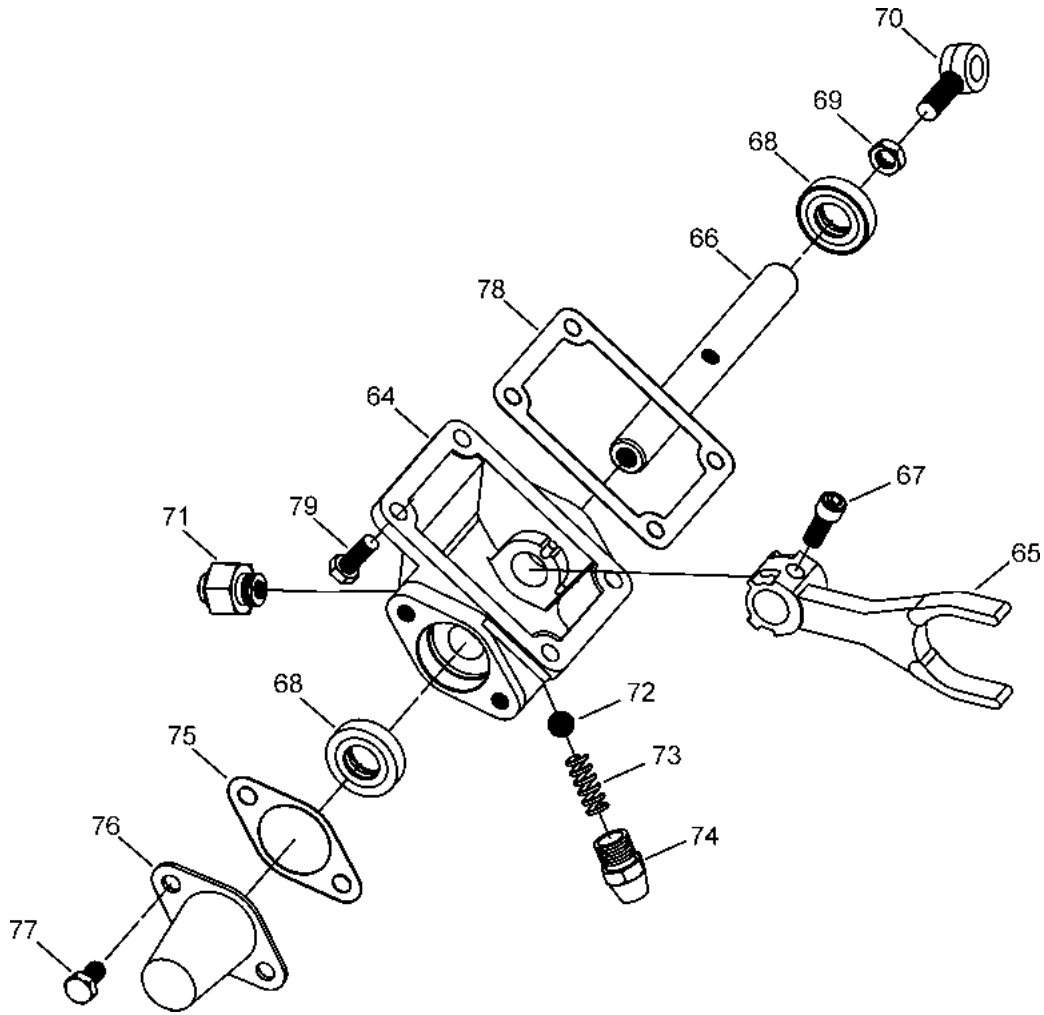

Item	Part Number	Description	Quantity
	329035-1X	Shifter Cover Assy, Lever Control (Assy 3 & 6)	1
		All the assemblies shown above include items 64 thru 78	
64	34-P-87	Shifter Cover	1
65	32-P-166	Shifter Fork	1
66	11-P-112	Shifter Shaft	1
67	378447-4	Capscrew, Socket Head (.312"-18 x .750")	1
68	28-P-207	Oil Seal	2
69	500381-3	Hex Lock Nut (.375"-24)	1
70	36-P-1	Eye Bolt	1
71	379639	Indicator Switch	1
72	378002	Poppet Ball	1
73	37-P-41	Poppet Spring	1
74	378554	Poppet Cap	1
75	35-P-14	Gasket, Shift Shaft Cover	1
76	35-P-23	Shifter Shaft Cover	1
77	378430-4	Capscrew, Hex Head (.312"-18 x .500")	2
78	35-P-8	Gasket, Shift Cover	1
79	378430-8	Capscrew, Hex Head (.312"-18 x .750")	4

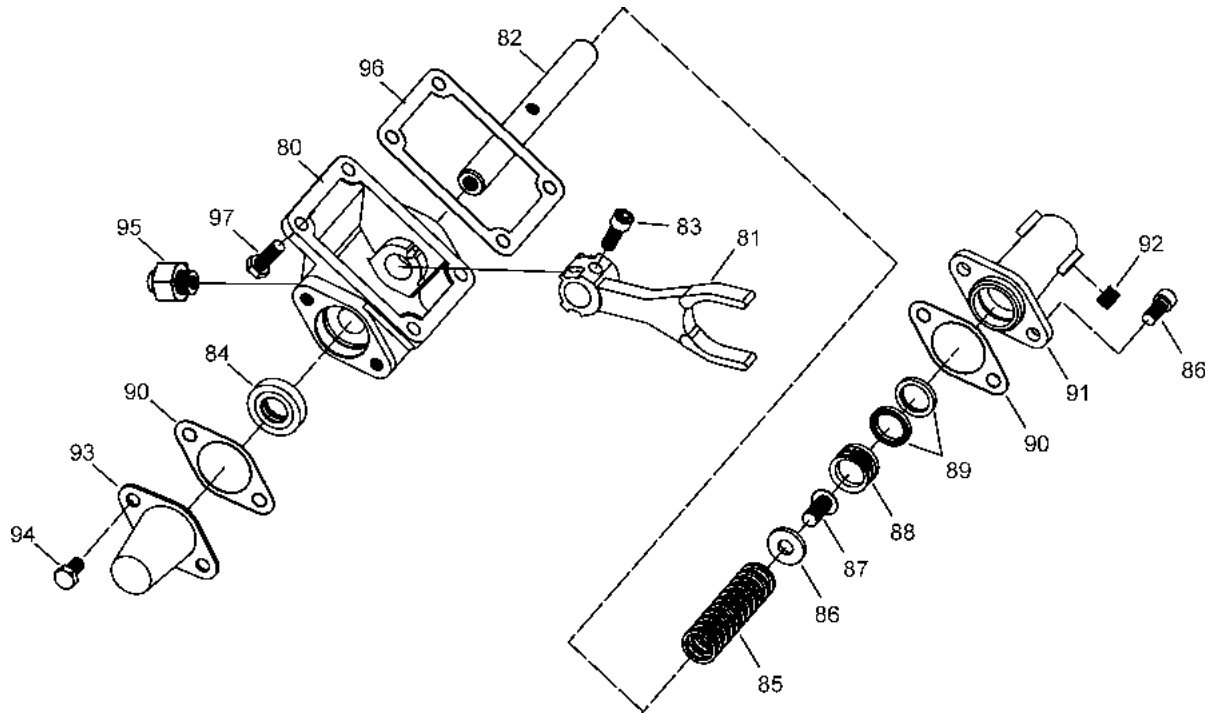

Item	Part Number	Description	Quantity
	329036-1X	Shifter Cover Assy, Air Shift (Assy 3 & 6).....	1
		All the assemblies shown above include items 80 thru 96	
80	34-P-76	Shifter Cover	1
81	32-P-166	Shifter Fork	1
82	11-P-112	Shifter Shaft	1
83	378447-4	Capscrew, Socket Head (.312"-18 x .750")	3
84	28-P-207	Oil Seal	1
85	37-P-25	Return Spring.....	1
86	378462	Washer.....	1
87	378908	Button Head Capscrew	1
88	66-P-4	Piston	1
89	28-P-41	O-Ring.....	2
90	35-P-14	Gasket, Shifter Shaft Cover	1
91	65-P-14	Cylinder	1
92	379231	Pipe Plug	1
93	65-P-23	Shifter Shaft Cover.....	1
94	378430-4	Cap Screw, Hex Head (.312"-18 x .500")	2
95	379639	Indicator Switch.....	1
96	35-P-8	Gasket, Shifter Cover	1
97	378430-8	Capscrew, Hex Head (.312"-18 x .750")	4
		Air Shift Conversion Kits	
	328390-85X	Lever To Air Shift	1
	328390-105X	Lever to Electric Over Air 12V	1
	328390-106X	Lever to Electric Over Air 24V	1
	328390-117X	Cable to Air (Assy 3 & 6)	1
	328390-119X	Cable to Electric/Air 12V (Assy 3 & 6)	1
	328390-120X	Cable to Electric/Air 24V (Assy 3 & 6)	1
		SHIFTER KITS	
	329106-39X	Shifter Kit (Air Shift 3 & 6, "A" shift option)	1
	329106-41X	Shifter Kit (Air Shift 3 & 6, "V" shift option)	1
	329106-43X	Shifter Kit (Air Shift 3 & 6, "P" shift option)	1
	329106-45X	Shifter Kit (Air Shift 3 & 6, "Q" shift option)	1
	329106-47X	Shifter Kit (Lever Shift 3 & 6, "Y" shift option)	1
	329106-105X	Shifter Kit (Wire Control 3 & 6, Q,W,X ratio; "W" shift option)	1
	329106-107X	Shifter Kit (Wire Control 3 & 6, Q,W,X ratio; "X" shift option)	1
	329106-109X	Shifter Kit (Wire Control 3 & 6, F,L,R,S,U ratio; "W" shift option)	1
	329106-111X	Shifter Kit (Wire Control 3 & 6, F,L,R,S,U ratio; "X" shift option)	1
	329106-125X	Shifter Kit (Easy Shift 12V, 3 & 6)	1
	329143X	Field Conversion Kit (Shifter Shaft)	1

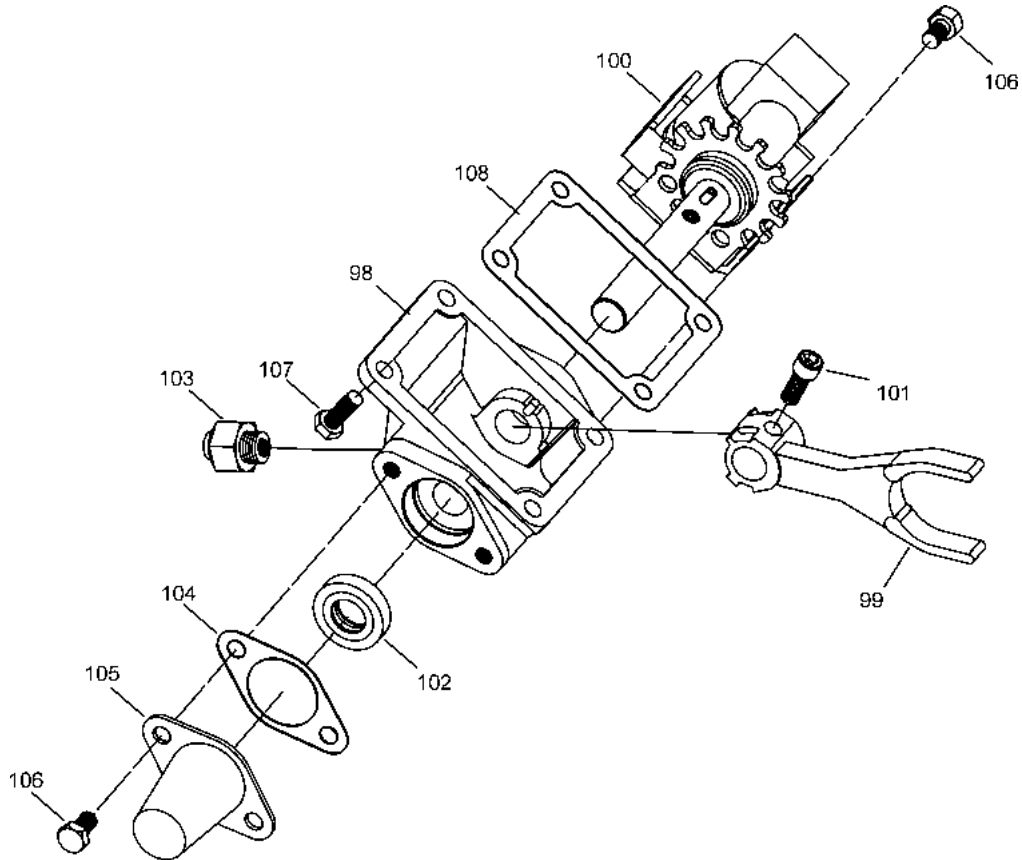

Item	Part Number	Description	Quantity
	329165-1X	Shifter Cover Assy, 12V (Assy 3 & 6)	1
		All the assemblies shown above include items 98 thru 106	
98	34-P-76	Shifter Cover	1
99	32-P-166	Shifter Fork	1
100	329225-12X	Electric Shift Ass'y	1
101	378447-4	Cap Screw, Socket Head (.312"-18 x .750")	1
102	28-P-207	Oil Seal	1
103	379639	Indicator Switch	1
104	35-P-14	Gasket, Shifter Shaft Cover	1
105	65-P-23	Shifter Shaft Cover	1
106	378430-4	Capscrew, Hex Head (.312"-18 x .500")	4
107	378430-8	Capscrew, Hex Head (.312"-18 x .750")	4
108	35-P-8	Gasket, Shifter Cover	1
		E-Z SHIFT CONVERSION KITS	
	328390-138X	Cable To E-Z Shift (Assy 3 & 6)	1
	328390-140X	Lever to E-Z Shift	1

Flange Suffix	Flange Type	Shaft Type	Conversion Kit
AA	Special For England	.982"-6 Spline	-
AF	S.A.E. "BB" 2 or 4 Bolt	1.0"-15 Spline	328591-30X
AK	S.A.E. "B" 2 BOLT	7/8"-13 Spline	328591-28X
AZ	Non-Standard 4 Bolt	1-1/4"-14 Spline	328591-70X
FF	S.A.E. "B" 2 or 4 Bolt	7/8" Round	328591-29X
GA	Rotatable S.A.E. "B" 2 Bolt	7/8"-13 Spline	■ 328591-72X
GB	Rotatable S.A.E. "B" 4 Bolt	7/8"-13 Spline	■ 328591-74X
GF	S.A.E. "BB" 2 or 4 Bolt	1.0"-15 Spline	■ 328591-71X
GH	Rotatable S.A.E. "BB" 2 Bolt	1.0"-15 Spline	■ 328591-89X
GK	S.A.E. "B" 2 or 4 Bolt	7/8"-13 Spline	■ 328591-116X
GP	S.A.E. "A" Pilot 2 or 4 Bolt	7/8"-13 Spline	■ 328591-90X
● GQ	S.A.E. "B" 2 or 4 Bolt	7/8"-13 Spline	■ 328591-91X
GR	CHELSEA Special 4 Bolt	7/8"-13 Spline	■ 328591-76X
GY	DIN 5462 Pump Mounting	DIN 5462	■ 328591-92X
GZ	Non-Standard 4 Bolt	1-1/4"-14 Spline	■ 328591-93X
RA	Rotatable S.A.E. "B" 2 Bolt	7/8"-13 Spline	328591-44X
RB	Rotatable S.A.E. "B" 4 Bolt	7/8"-13 Spline	328591-56X
RC	Rotatable S.A.E. "A" 2 Bolt	5/8"-9 Spline	328591-78X
RD	Rotatable S.A.E. "A" 2 Bolt	7/8"-13 Spline	328591-112X
RF	Rotatable S.A.E. "BB" 2 Bolt	1.0"-15 Spline	328591-113X
XE	S.A.E. "A" 2 or 4 Bolt	5/8"-9 Spline	328591-27X
XG	Non-Standard 4 Bolt	3/4" Round	328591-10X
XJ	Non-Standard 4 Bolt	3/4" Round	328591-11X
XK	S.A.E. "B" 2 or 4 Bolt	7/8"-13 Spline	328591-16X
XL	Non-Standard 4 Bolt	7/8"-13 Spline	328591-18X
XO	S.A.E. "A" Pilot 2 Bolt	3/4" Round	328591-26X
XP	S.A.E. "A" Pilot 2 or 4 Bolt	7/8"-13 Spline	328591-23X
● XQ	S.A.E. "B" 2 or 4 Bolt	7/8"-13 Spline	328591-17X
XR	CHELSEA Special 4 Bolt	7/8"-13 Spline	328591-52X
XY	DIN 5462 Pump Mounting	7/8"-13 Spline	328591-121X
XX	S.A.E. Taper Shaft	1.250" S.A.E. Taper	328591-122X

NOTE: "XR" to "XK" Conversion Flange 21-P-525

■ Shaft with Grease Fitting

● Similar to Ass'y "XK" Flange Rotated 90°

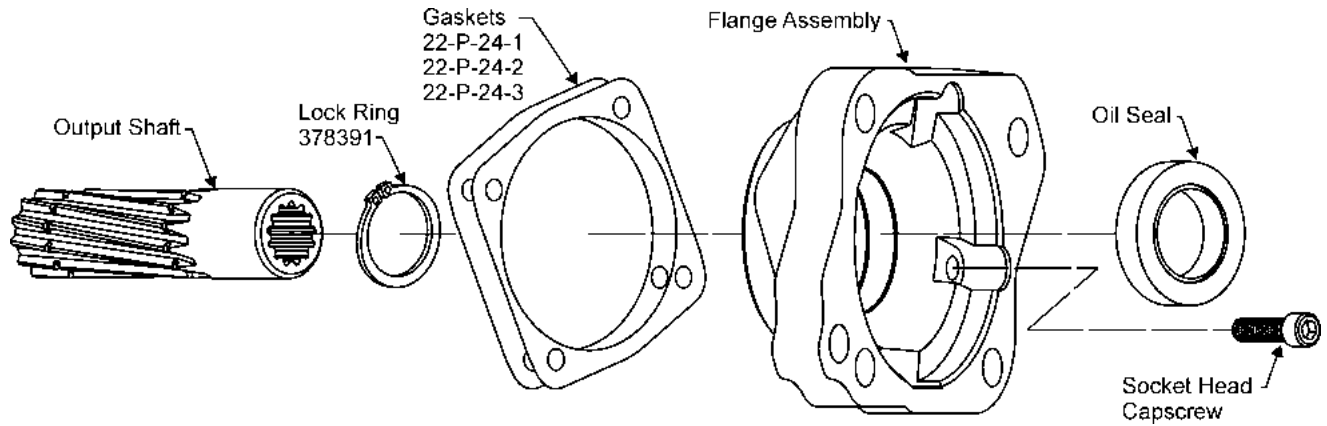

Flange Suffix	Conversion Kit*	Front				Rear Cap Greaseable Option		
		Flange Assembly	Output Shaft	Socket Head (4 Req'd)	Oil Seal	Brg. Cap Assembly	Socket Head (4 Req'd)	Oil Seal
AA		329102X	3-P-862	378447-8	28-P-216			
AF	328591-30X	329088X	3-P-854	378447-10	28-P-216			
AK	328591-28X	329089X	3-P-282	378447-8	28-P-216			
AZ	328591-70X	329052X	3-P-844	378447-11	28-P-230			
FF	328591-29X	329088X	3-P-851	378447-10	28-P-216			
GA	328591-72X	329195X	3-P-923X	●378447-6	28-P-216	328273X	378430-1	28-P-268
GB	328591-74X	329195X	3-P-923X	●378447-6	28-P-216	328273X	378430-1	28-P-268
GF	328591-71X	329088X	3-P-921X	378447-10	28-P-216	328273X	378430-1	28-P-268
GH	328591-116X	378447-6 21-P-626	3-P-941X	378447-6 tt	28-P-216	328273X	378430-10	28-P-268
GK	328591-89X	329333X	3-P-933X	378447-8	28-P-216	328273X	378430-1	28-P-268
GP	328591-90X	329328X	3-P-933X	378447-8	28-P-216	328273X	378430-1	28-P-268
■ GQ	328591-91X	329589X	3-P-933X	378447-8	28-P-216	328273X	378430-1	28-P-268
GR	328591-76X	329194X	3-P-923X	▶379673	28-P-216	328273X	378430-1	28-P-268
GY	328591-82X	329234X	3-P-938X	378430-10	28-P-216	328273X	378430-1	28-P-268
GZ	328591-93X	329052X	3-P-939X	378447-11	28-P-230	328273X	378430-1	28-P-268
RA	328591-55X	329195X 21-P-628	3-P-283	●378447-6	28-P-216			
RB	328591-56X	329195X 21-P-572	3-P-283	●378447-6	28-P-216			
RC	328591-112X	329322X 21-P-638	3-P-800	328170-210X	28-P-216			
RD	328591-113X	329322X 21-P-638	3-P-282	328170-210X	28-P-216			
RF	328591-78X	329264X 21-P-626	3-P-924	●378447-6	28-P-216			
XE	328591-27X	329328X	3-P-800	378447-8	28-P-216			
XG	328591-10X	329580X	3-P-281	378447-8	28-P-216			
XJ	328591-11X	329580X	3-P-284	378447-8	28-P-216			
XK	328591-16X	329333X	3-P-282	378447-8	28-P-216			
XL	328591-18X	329580X	3-P-283	378447-8	28-P-216			
XM	328591-20X	329583X	3-P-284	378447-8	28-P-216			
XN	328591-21X	328584X	3-P-282	378447-8	28-P-216			
XO	328591-26X	329328X	3-P-284	378447-8	28-P-216			
XP	328591-23X	329328X	3-P-282	378447-8	28-P-216			
■ XQ	328591-17X	329589X	3-P-282	378447-8	28-P-216			
XR	328591-52X	329194X	3-P-283	▶379673	28-P-216			
XY	328591-121X	329324X	3-P-768	378430-10	28-P-230			
XX	328591-122X	328273X	3-P-766	378430-10	28-P-216			

● Seven required; four to fasten the Flange Assembly 328195X to the housing and three to fasten the rotatable flange to the flange assembly

■ Similar to "XK" Assembly, only rotated 90°

▶ Special shoulder stud

* Consists of all the items shown in the illustration, plus Lockring (Item 5) and Bearing Cap Gasket (Item 8)

NOTE: The 489 "A" & "C" ratio units cannot be used with an "XK" or "AK" output flange due to interference.

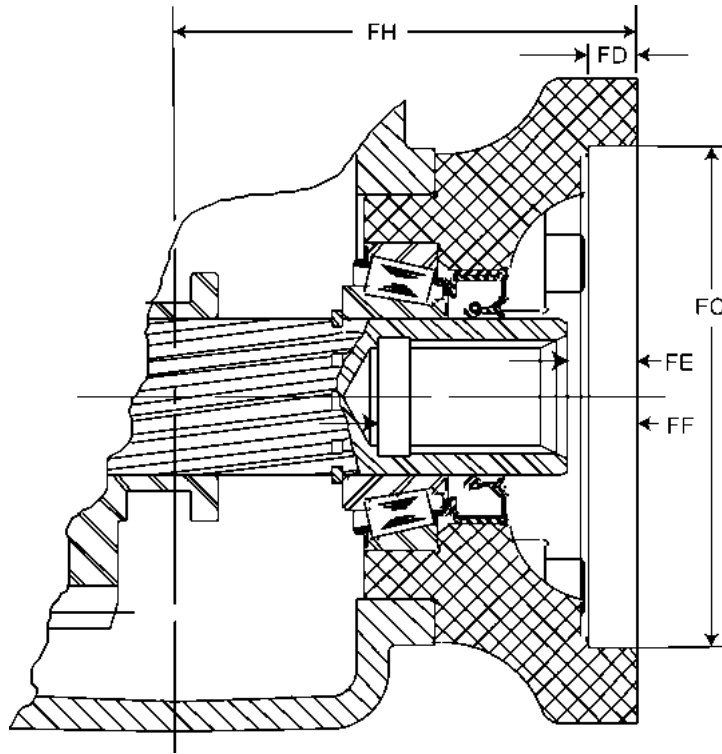

Pump Flange Suffix	Bolt Circle Dia.	BOLT HOLES		FC Female Pilot Diameter	FD Pilot Depth	FE Face to end of Shaft	FF Face thru Hole	FH Face to Center of P.T.O.	OUTPUT SHAFT Hole Dia.
		Tapped Hole	No. Equally Spaced						
AA	2.834	M10-1.5	6	2.050	N/A	N/A	N/A	3.447	.982/.816 - 6 Spline
AF, GF	5.750	.500"-13	2	4.003	0.406	0.516	1.984	4.322	1"-15 Spline
	5.000	.500"-13	4	4.003	0.406	0.516	1.984	4.322	
AK	5.750	.500"-13	2	4.003	0.406	0.562	2.062	3.688	7/8" - 13 Spline
AZ, GZ	5.000	.500"-13	4	4.003	0.406	0.695	2.392	4.985	1-1/4" - 14 Spline
FF	5.750	.500"-13	2	4.003	0.406	0.516	1.984	4.322	7/8" Round
	5.000	.500"-13	4	4.003	0.406	0.516	1.984	4.322	
●RA, GA	5.750	.500"-13	2 ■	4.003	0.406	0.558	2.058	4.588	7/8"-13 Spline
●RB, GB	5.000	.500"-13	4	4.003	0.406	0.558	2.058	4.588	7/8"-13 Spline
●RC	4.188	.375"-16	2 ■	3.253	0.270	0.525	1.462	3.694	5/8" Round
●RD	4.188	.375"-16	2 ■	4.003	0.406	0.525	1.462	3.694	7/8" -13 Spline
●RF, GH	5.750	.500"-13	2 ■	4.003	0.406	0.501	1.969	4.569	1"-15 Spline
XE	5.000	.500"-13	4	3.253	0.344	0.562	1.500	3.688	5/8"- 9 Spline
XG	4.188	.375"-16	4	3.253	0.562	0.593	2.218	4.562	3/4" Round
XJ	4.188	.375"-16	4	3.253	0.562	1.406	2.906	4.562	3/4" Round
XL	4.188	.375"-16 ▶	4	3.253	0.562	0.562	2.062	4.562	7/8"-13 Spline
XK	5.750	.500"-13 ▶	2	4.003	0.406	0.562	2.062	3.688	7/8"-13 Spline
	5.000	.500"-13	4	4.003	0.406	0.562	2.062	3.688	
XY, GY	4.454	M12-1.75	4	3.152	0.393	0.594	2.508	4.697	DIN 5462
XO	5.000	.500"-13	4	3.253	0.344	0.562	2.062	3.688	3/4" Round
	4.188	.375"-16	2	3.253	0.344	0.562	2.062	3.688	
XP, GP	5.000	.500"-13	4	3.253	0.344	0.562	2.062	3.688	7/8"-13 Spline
	4.188	.375"-16	2	3.253	0.344	0.562	2.062	3.688	
XQ, GQ	5.750	.500"-13	2	4.003	0.406	0.562	2.062	3.688	7/8"-13 Spline
	5.000	.500"-13	4	4.003	0.406	0.562	2.062	3.688	
XR, GR	3.710	.312"-24(Studs)	4	2.752	0.281	N/A	N/A	2.809	7/8"-13 Spline

- Rotatable Flange Rotates in 30° Increments
- Two Set of Holes Spaced 14° Apart
- ▶ Not Tapped

NOTE: To convert an "XR" to an "XK", use conversion flange number 21-P-525

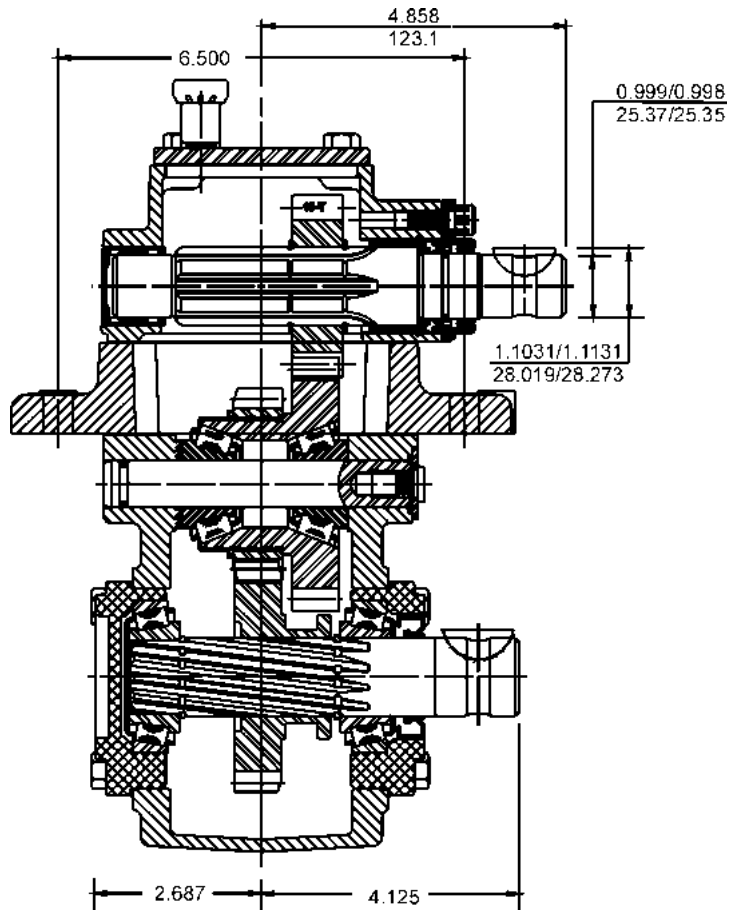
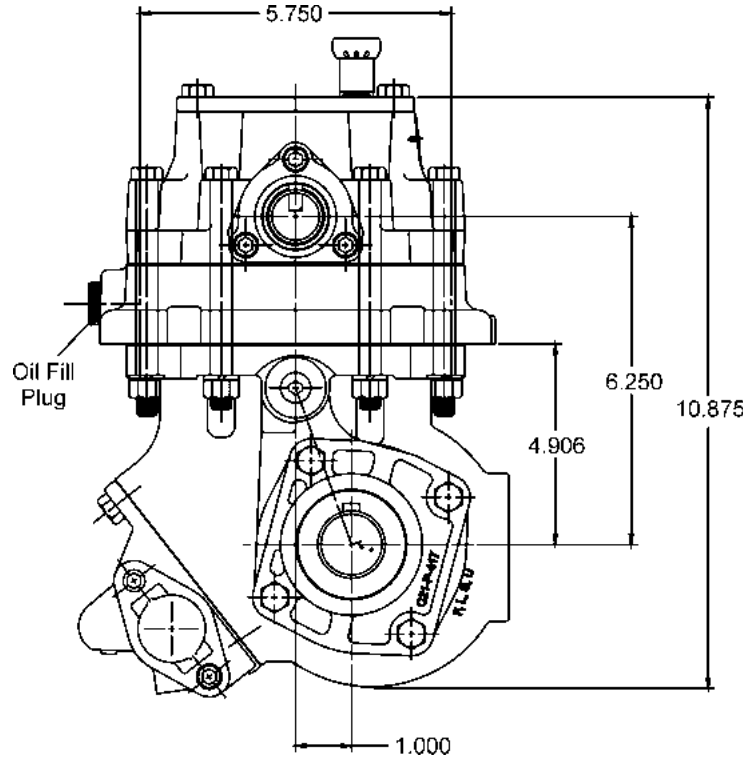

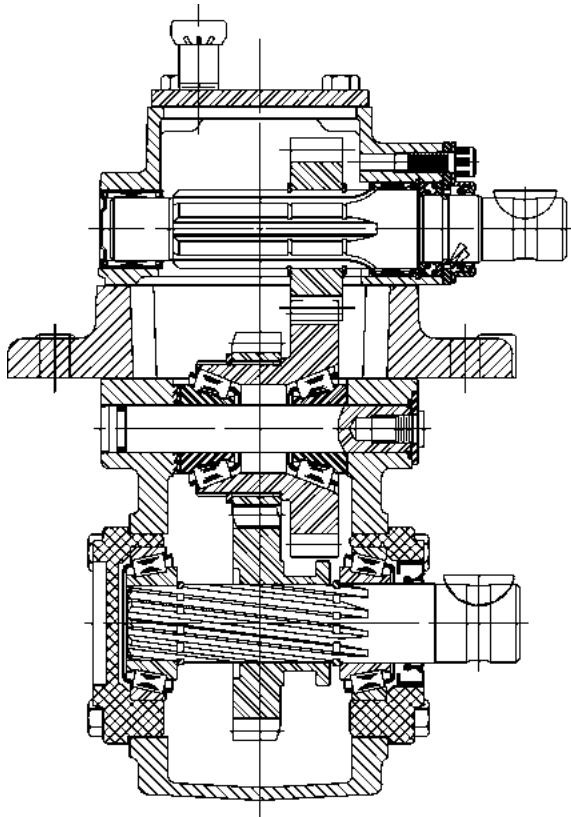

1

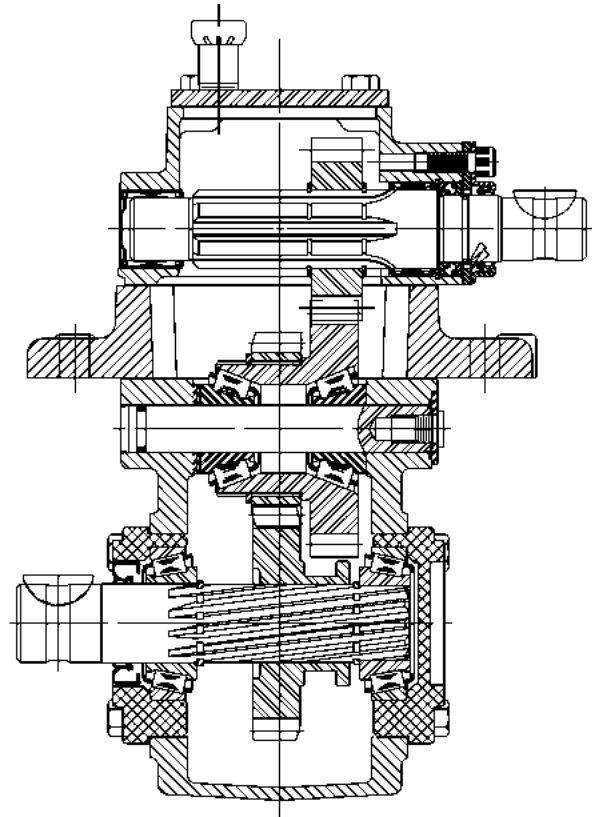

2

Model Number Designation

2442 - **W** **2** **XD**
BASIC MODEL
 2442F = .390:1
 2442L = .500:1
 2442Q = .540:1
 2442S = .740:1
 2442U = .890:1
 2442W = 1.040:1
 2442X = 1.230:1
SHIFTER TYPE
 A = Air Shift
 H = No Shifter
 P = Air Shift 12V
 Q = Air Shift 24V
 W = Cable Shift
 X = Less Cable & Knob
 Y = Lever Shift
 Z = E-Z Shift
 S = Air Shift with Control Valve
 T = P.T.O. & Dump Pump Combo
 Valve Less Kick-out
 U = P.T.O. & Pump Valve with Kick
 out Less Neutral Spring Return

OUTPUT TYPE

XD = 1.250" Rd Std. Shaft
 XG = S.A.E. "A" 2 Bolt
 XK = S.A.E. "B" 2 or 4 Bolt
 XO = S.A.E. "A" 2 Bolt
 XQ = S.A.E. "B" 2 or 4 Bolt
 XX = 1.250" S.A.E. Taper
 AK = S.A.E. "B" 2 Bolt
 AZ = S.A.E. "B" 4 Bolt 1.250" 14T
 RA = Rotatable "B" 2 Bolt
 RC = Rotatable S.A.E. "A" 2 Bolt
 RF = Rotatable "BB" 2 Bolt
 GA = Greaseable Rotatable "B"
 GB = Greaseable Rotatable "B"
 GF = Greaseable S.A.E. "BB" 2
 GH = Rotatable S.A.E. "BB" 2 Bolt
 GR = Greaseable CHELSEA Special
 GZ = Greaseable S.A.E. "B" 4 Bolt 1.250" 14T
 XE = S.A.E. "A" 2 or 4 Bolt
 XJ = S.A.E. "A" 2 Bolt
 XL = S.A.E. "A" 2 Bolt
 XP = S.A.E. "A" 2 Bolt
 XR = CHELSEA Special
 XY = DIN 5462
 AF = S.A.E. "BB" 2 or 4 Bolt
 FF = S.A.E. "B" 2 or 4 Bolt
 RB = Rotatable "B" 4 Bolt
 RD = Rotatable S.A.E. "A" 2 Bolt
 GR = Greaseable CHELSEA Special
 GP = Greaseable S.A.E. "A" 2 or 4 Bolt
 GY = Greaseable DIN 5462 Flange w/ 1.245" 12T
 GK = Greaseable S.A.E. "B" 2 or 4 Bolt
 GQ = Greaseable S.A.E. "B" 2 or 4 Bolt

ASSEMBLY ARRANGEMENT

1 = Output Opposite Input
 2 = Output Same Side as Input

Offer of Sale

The items described in this document and other documents or descriptions provided by Parker Hannifin Corporation, its subsidiaries and its authorized distributors are hereby offered for sale at prices to be established by Parker Hannifin Corporation, its subsidiaries and its authorized distributors. This offer and its acceptance by any customer ("Buyer") shall be governed by all of the following Terms and Conditions. Buyer's order for any such items, when communicated to Parker Hannifin Corporation, its subsidiary or an authorized distributor ("Seller") verbally or in writing, shall constitute acceptance of this offer.

1. Terms and Conditions of Sale: All descriptions, quotations, proposals, offers, acknowledgments, acceptances and sales of Seller's products are subject to and shall be governed exclusively by the terms and conditions stated herein. Buyer's acceptance of any offer to sell is limited to these terms and conditions. Any terms or conditions in addition to, or inconsistent with those stated herein, proposed by Buyer in any acceptance of an offer by Seller, are hereby objected to. No such additional, different or inconsistent terms and conditions shall become part of the contract between Buyer and Seller unless expressly accepted in writing by Seller. Seller's acceptance of any offer to purchase by Buyer is expressly conditional upon Buyer's assent to all the terms and conditions stated herein, including any terms in addition to, or inconsistent with those contained in Buyer's offer. Acceptance of Seller's products shall in all events constitute such assent.

2. Payment: Payment shall be made by Buyer net 30 days from the date of delivery of the items purchased hereunder. Amounts not timely paid shall bear interest at the maximum rate permitted by law for each month or portion thereof that the Buyer is late in making payment. Any claims by Buyer for omissions or shortages in a shipment shall be waived unless Seller receives notice thereof within 30 days after Buyer's receipt of the shipment.

3. Delivery: Unless otherwise provided on the face hereof, delivery shall be made F.O.B. Seller's plant. Regardless of the method of delivery, however, risk of loss shall pass to Buyer upon Seller's delivery to a carrier. Any delivery dates shown are approximate only and Seller shall have no liability for any delays in delivery.

4. Warranty: Seller warrants that the items sold hereunder shall be free from defects in material or workmanship for a period of:

(A) All Power Take-Off units one (1) year from date of installation.

(B) Except 267, 277, 278, 242, 244, 250, 251 and 859 series two (2) years from date of installation. **THIS WARRANTY COMPRISES THE SOLE AND ENTIRE WARRANTY PERTAINING TO ITEMS PROVIDED HEREUNDER. SELLER MAKES NO OTHER WARRANTY, GUARANTEE, OR REPRESENTATION OF ANY KIND WHATSOEVER. ALL OTHER WARRANTIES, INCLUDING BUT NOT LIMITED TO, MERCHANTABILITY AND FITNESS FOR PURPOSE, WHETHER EXPRESS, IMPLIED, OR ARISING BY OPERATION OF LAW, TRADE USAGE, OR COURSE OF DEALING ARE HEREBY DISCLAIMED. NOTWITHSTANDING THE FOREGOING, THERE ARE NO WARRANTIES WHATSOEVER ON ITEMS BUILT OR ACQUIRED WHOLLY OR PARTIALLY, TO BUYER'S DESIGNS OR SPECIFICATIONS.**

5. Limitation Of Remedy: SELLER'S LIABILITY ARISING FROM OR IN ANY WAY CONNECTED WITH THE ITEMS SOLD OR THIS CONTRACT SHALL BE LIMITED EXCLUSIVELY TO REPAIR OR REPLACEMENT OF THE ITEMS SOLD OR REFUND OF THE PURCHASE PRICE PAID BY BUYER, AT SELLER'S SOLE OPTION. IN NO EVENT SHALL SELLER BE LIABLE FOR ANY INCIDENTAL, CONSEQUENTIAL OR SPECIAL DAMAGES OF ANY KIND OR NATURE WHATSOEVER, INCLUDING BUT NOT LIMITED TO LOST PROFITS ARISING FROM OR IN ANY WAY CONNECTED WITH THIS AGREEMENT OR ITEMS SOLD HEREUNDER, WHETHER ALLEGED TO ARISE FROM BREACH OF CONTRACT, EXPRESS OR IMPLIED WARRANTY, OR IN TORT, INCLUDING WITHOUT LIMITATION, NEGLIGENCE, FAILURE TO WARN OR STRICT LIABILITY.

6. Changes, Reschedules and Cancellations: Buyer may request to modify the designs or specifications for the items sold hereunder as well as the quantities and delivery dates thereof, or may request to cancel all or part of this order, however, no such requested modification or cancellation shall become part of the contract between Buyer and Seller unless accepted by Seller in a written amendment to this Agreement. Acceptance of any such requested modification or cancellation shall be at Seller's discretion, and shall be upon such terms and conditions as Seller may require.

7. Special Tooling: A tooling charge may be imposed for any special tooling, including without limitation, dies, fixtures, molds and patterns, acquired to manufacture items sold pursuant to this contract. Such special tooling shall be and remain Seller's property notwithstanding payment of any charges by Buyer. In no event will Buyer acquire any interest in apparatus belonging to Seller which is utilized in the manufacture of the items sold hereunder, even if such apparatus has been specially converted or adapted for such manufacture and notwithstanding any charges paid by Buyer. Unless otherwise agreed, Seller shall

have the right to alter, discard or otherwise dispose of any special tooling or other property in its sole discretion at any time.

8. Buyer's Property: Any designs, tools, patterns, materials, drawings, confidential information or equipment furnished by Buyer or any other items which become Buyer's property, may be considered obsolete and may be destroyed by Seller after two (2) consecutive years have elapsed without Buyer placing an order for the items which are manufactured using such property, Seller shall not be responsible for any loss or damage to such property while it is in Seller's possession or control.

9. Taxes: Unless otherwise indicated on the face hereof, all prices and charges are exclusive of excise, sales, use, property, occupational or like taxes which may be imposed by any taxing authority upon the manufacture, sale or delivery of the items sold hereunder. If any such taxes must be paid by Seller or if Seller is liable for the collection of such tax, the amount thereof shall be in addition to the amounts for the items sold. Buyer agrees to pay all such taxes or to reimburse Seller therefore upon receipt of its invoice. If Buyer claims exemption from any sales, use or other tax imposed by any taxing authority, Buyer shall save Seller harmless from and against any such tax, together with any interest or penalties thereon which may be assessed if the items are held to be taxable.

10. Indemnity For Infringement of Intellectual Property Rights: Seller shall have no liability for infringement of any patents, trademarks, copyrights, trade dress, trade secrets or similar rights except as provided in this Part 10. Seller will defend and indemnify Buyer against allegations of infringement of U.S. Patents, U.S. Trademarks, copyrights, trade dress and trade secrets (hereinafter 'Intellectual Property Rights'). Seller will defend at its expense and will pay the cost of any settlement or damages awarded in an action brought against Buyer based on an allegation that an item sold pursuant to this contract infringes the Intellectual Property Rights of a third party. Seller's obligation to defend and indemnify Buyer is contingent on Buyer notifying Seller within ten (10) days after Buyer becomes aware of such allegations of infringement, and Seller having sole control over the defense of any allegations or actions including all negotiations for settlement or compromise. If an item sold hereunder is subject to a claim that it infringes the Intellectual Property Rights of a third party, Seller may, at its sole expense and option, procure for Buyer the right to continue using said item, replace or modify said item so as to make it noninfringing, or offer to accept return of said item and return the purchase price less a reasonable allowance for depreciation. Notwithstanding the foregoing, Seller shall have no liability for claims of infringement based on information provided by Buyer, or directed to items delivered hereunder for which the designs are specified in whole or part by Buyer, or infringements resulting from the modification, combination or use in a system of any item sold hereunder. The foregoing provisions of this Part 10 shall constitute Seller's sole and exclusive liability and Buyer's sole and exclusive remedy for infringement of Intellectual Property Rights.

If a claim is based on information provided by Buyer or if the design for an item delivered hereunder is specified in whole or in part by Buyer, Buyer shall defend and indemnify Seller for all costs, expenses or judgments resulting from any claim that such item infringes any patent, trademark, copyright, trade dress, trade secret or any similar right.

11. Force Majeure: Seller does not assume the risk of and shall not be liable for delay or failure to perform any of Seller's obligations by reason of circumstances beyond the reasonable control of Seller (hereinafter 'Events of Force Majeure'). Events of Force Majeure shall include without limitation, accidents, acts of God, strikes or labor disputes, acts, laws, rules or regulations of any government or government agency, fires, floods, delays or failures in delivery of carriers or suppliers, shortages of materials and any other cause beyond Seller's control.

12. Entire Agreement/Governing Law: The terms and conditions set forth herein, together with any amendments, modifications and any different terms or conditions expressly accepted by Seller in writing, shall constitute the entire Agreement concerning the items sold, and there are no oral or other representations or agreements which pertain thereto. This Agreement shall be governed in all respects by the law of the State of Ohio. No actions arising out of the sale of the items sold hereunder or this Agreement may be brought by either party more than two (2) years after the cause of action accrues.

9/01-P



Parker Hannifin Corporation
Chelsea Products Division
8225 Hacks Cross Road
Olive Branch, Mississippi 38654 USA
Tel: (662) 895-1011
Fax: (662) 895-1019
www.parker.com/chelsea

FP 12/01 5M